

SEHD

Energy-efficient Hopper Dryer

Date: June 2026

Version: Ver.C



Content

1. General Description	4
1.1 Coding Principle.....	5
1.2 Feature	5
1.3 Safety Regulations.....	7
1.3.1 Safety Signs and Labels.....	7
1.4 Exemption Clause.....	8
2. Structure Characteristics and Working Principle.....	9
2.1 Working Principle	9
2.2 Options	10
2.2.1 Air Filter	10
2.2.2 Blower Inlet Filter.....	10
2.2.3 Magnetic Base.....	10
2.2.4 Hot Air Recycler	11
2.2.5 Hopper Magnet.....	11
2.2.6 N-Type Floor Stand	12
3. Installation and Debugging	13
3.1 Direct Installation	13
3.2 Floor Stand Installation	14
3.3 Connecting the Power Source	15
3.4 The Hopper Dryer Test	15
4. Operation Guide	16
4.1 Control Panel	16
4.1.1 Panel Operation	16
4.1.2 Temperature Setting.....	16
4.1.3 Temperature Lock	16
4.1.4 PID Setting	17
4.1.5 Intermittent Operation Setting.....	18
4.1.6 One-week Timing Setting	18
4.1.7 Communication Setting (optional functions)	18
4.1.8 Operation Flow	20
4.1.9 Wrong Codes Remark.....	21

5. Maintenance and Repair	22
5.1 Blower.....	22
6. Troubleshooting	22

Picture Index

Picture 2-1: Working Principle	9
Picture 3-1: Direct Installation.....	13
Picture 3-2: Floor Stand Installation	14
Picture 3-3: Blower	15
Picture 4-1: Control Panel	16

1. General Description



Please read through this operation manual before using the machine to prevent damages of the machine or personal injuries.



SEHD-200

1.1 Coding Principle

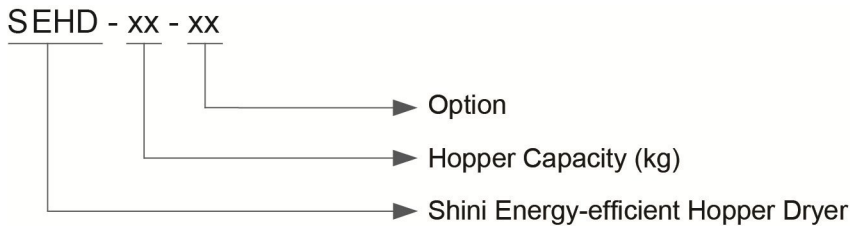

1.2 Feature

Optimal structure

- I Down-blowing structure design reduces the different between inlet air temperature and heater temperature to ensure stable inlet air temperature.
- I Adopt heat-insulated blower to prolong blower lifespan.
- I The heating tank adopts double-layer insulation structure which not only can reduce the power consumption but also can avoid too high of the ambient temperature.
- I All material contact surfaces are made of stainless steel to eliminate material contamination.
- I Hopper separated from its base with cleaning door (except SEHD-12&25) for easy cleanliness.
- I Models above SEHD-200 are equipped with the magnetic base.
- I The SEHD-200~600 models are equipped with standard magnet bases, and SEHD-800~1000 models adopt manual butterfly valve with standard floor stand

User-friendly design

- I SEHD-25-150 pipe heater with lead sheet connected and all series are equipped with the temperature protector as to prevent the pipe heater from dry burning.
- I With overheat release function, when the drying temperature exceeds the set deviation value, the main power supply will be automatically cut off.
- I All series are standard equipped with the one-week timer and intermittent operation function.
- I All series are equipped with microcomputer control and RS485 communication interface.

- I The max. drying temperature can reach 160°C.

Energy efficient

- I Compared with the test of standard SHD hopper dryer, the drying effect of SEHD increased by 60% on average, while the power consumption decreased by 40%.

All service work should be carried out by a person with technical training or corresponding professional experience. The manual contains instructions for both handling and servicing. Chapter 5, which contains service instructions intended for service engineers. Other chapters contain instructions for the daily operator.

Any modifications of the machine must be approved by SHINI in order to avoid personal injury and damage to machine. We shall not be liable for any damage caused by unauthorized change of the machine.

Our company provides excellent after-sales service. Should you have any problem during using the machine, please contact the company or the local vendor.

Headquarter and Taipei factory:

Tel: (886) 2 2680 9119

Shini Plastics Technologies (Dongguan), Inc:

Tel: (86) 769 8111 6600

Shini Plastics Technologies India Pvt.Ltd.:

Tel: (91) 250 3021 166

1.3 Safety Regulations

1.3.1 Safety Signs and Labels



Note!

Electrical installation should be done by qualified electrician only.

Before connecting to AC Power Source, turn power switch to OFF position.

While AC power source is connected, make sure specifications and overload protection rating of the power switch are suitable and reliable.

When the machine is under care or maintenance, turn off both power switch and automatic operation switch.

	<p>Danger! High pressure! It is attached to the control box.</p>
	<p>Warning! High temperature surface may burn hands! It is attached on the cover of pipe heater.</p>
	<p>Attention! This mark reminds you to be more careful!</p>
	<p>Warning! High temperature surface may burn hands! This label should be stick to the shell of electric heating box.</p>
<p>⚠ 超溫時，保護裝置動作；解除故障後，按藍色鍵復位並合上開關，重新通電運行。 Protection device activates when overheat occurs; after faults are discharged, press blue key to reset and turn on the switch to restart operation.</p> <p>超溫保護裝置 Overheat protection device</p>	<p>Protection device activates when overheat occurs; after faults are discharged, press blue key to reset and turn on the switch to Restart operation.</p>
	<p>Push-and-pull switch for shut-off plate: I: Means "Pull" O: Means "Push"</p>
<p>請定期清理過濾網以免阻塞而影響乾燥 Regularly clean the filter screen to avoid insufficient drying caused by blocking.</p>	<p>Regularly clean the filter screen to avoid insufficient drying caused by blocking</p>

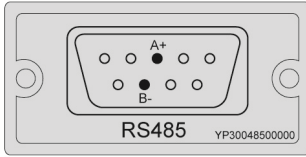

Communication interface RS485

1.4 Exemption Clause

The following statements clarify the responsibilities and regulations born by any buyer or user who purchases products and accessories from Shini (including employees and agents).

Shini is exempted from liability for any costs, fees, claims and losses caused by reasons below:

1. Any careless or man-made installations, operation and maintenances upon machines without referring to the Manual prior to machine using.
2. Any incidents beyond human reasonable controls, which include man-made vicious or deliberate damages or abnormal power, and machine faults caused by irresistible natural disasters including fire, flood, storm and earthquake.
3. Any operational actions that are not authorized by Shini upon machine, including adding or replacing accessories, dismantling, delivering or repairing.
4. Employing consumables or oil media that are not appointed by Shini.

2. Structure Characteristics and Working Principle

2.1 Working Principle

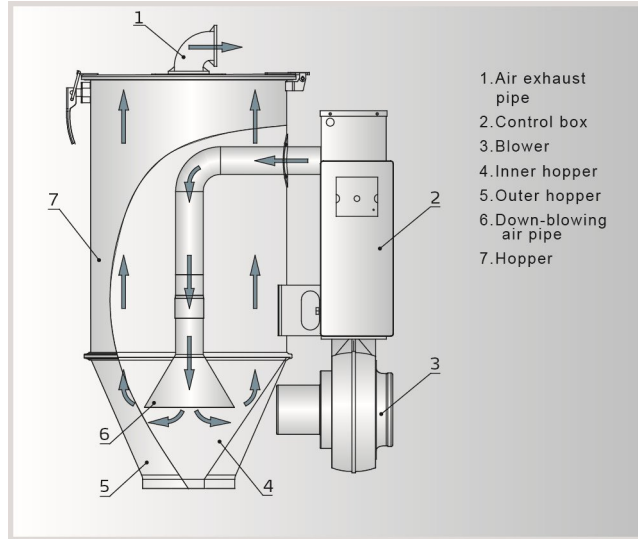

Picture 2-1: Working Principle

The air blown out by the blower is heated by electric heating to form the high-temperature dry hot air. Through down-blowing air pipe and hopper bell, the hot air can be evenly blown upward from the hopper bottom. The plastic materials absorb the heat in the air, and the drying air temperature gradually decreases, so the temperature of materials at lower part of the drying hopper is higher than that in the upper part. The material enters the drying hopper from the upper part and is excluded from the bottom as to ensure the drying effect.

2.2 Options

2.2.1 Air Filter



Model	Diameter(mm)	Height(mm)	Applied to
ADC-2	205	728	SEHD-25~150
ADC-3	246	1024	SEHD-200~1000

Effectively filter 99% of dust-contain air discharged from dryer to avoid air pollution.

2.2.2 Blower Inlet Filter



Model	Diameter(mm)	Height(mm)	Applied to
AIF-12	157	195	SEHD-12
AIF-25	157	195	SEHD-25
AIF-50	177	201	SEHD-50/75
AIF-100	219	191	SEHD-100/150
AIF-200	249	268	SEHD-200~300
AIF-600	221	380	SEHD-400~600
AIF-800	221	380	SEHD-800~1000

Notes: refill air input of the blower is adjustable.

2.2.3 Magnetic Base



Model	Applied to	Magnetic Frame	Height(mm)	Aluminum Holder×2
MB-12	SEHD-12	MR-3	193	88.5 × 78 × 2.3
MB-50	SEHD-25~75		231	
MB-100	SEHD-100~150		193	118.5 × 105 × 2.3

Made of aluminum with built-in hopper magnet, can effectively separate metal scraps out to avoid material contamination. (The SEHD-200 and above models are equipped with the standard magnetic base.)

2.2.4 Hot Air Recycler



Model	Filtering Barrel Dia. (mm)	Inlet Air Pipe Dia. (inch)	Flange of Air Outlet (inch)	Applied to
HAR-12	157		2	SEHD-12
HAR-25EH	157		2.5	SEHD-25
HAR-50 EH	175		3	SEHD-50/75
HAR-100 EH	219		3	SEHD-100/150
HAR-200 EH	245		4	SEHD-200~300
HAR-600 EH	245		4	SEHD-400~600
HAR-800	245		4	SEHD-800~1000

Work with hopper dryer to make the hot air form a semi-closed circulated loop and has features as follows:

- 1) Hot air recycling and circulating avoids indoor temperature rising up.
- 2) Keep air in factory clean and ensure good product quality.
- 3) Heating by fast hot air circulation can lower energy consumption by 40%.

2.2.5 Hopper Magnet



Absorb metal scraps in the material to avoid the damage of molding screw.

Model	Applied to	Aluminum Holder×2 (mm)
MR-5	SHD-12	(148 x 80 x 2.3)
MR-7	SHD-25~75	(190 x 80 x 2.3)

2.2.6 N-Type Floor Stand

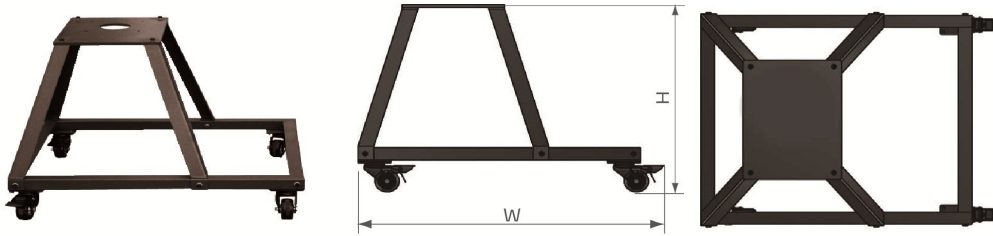

Model	Applied to	Dimension (mm) H×W×D	A / B / C (mm)
FSN-50	SEHD-12~75	600 × 700 × 640	140/54/ 9
FSN-100	SEHD-100/150	615 × 800 × 710	210/90/11
FSN-200	SEHD-200/300	680 × 1000 × 840	210/90/11
FSN-400	SEHD-400~600	700 × 1200 × 1010	260/116 /13
FSN-800	SEHD-800/1000	700 × 1600 × 1180	260/116/13

With which machines can be easily moved out of workplace which is suitable for the factories with height limited workshops, also it can make operations more convenient.

3. Installation and Debugging

Notes for Installation and Positioning:

- 1) Machine just can be mounted in vertical position. Make sure there's no pipe, fixed structure or other objects above the installing location and around the machine which may block machine's installation, hit objects or injure human person.
- 2) In order to maintain convenient operation, it's suggested to keep 1m space around the machine. Please keep at least 2m distance between the device and the inflammable goods.
- 3) This series of models only could be applied in working environment with good ventilation.

3.1 Direct Installation

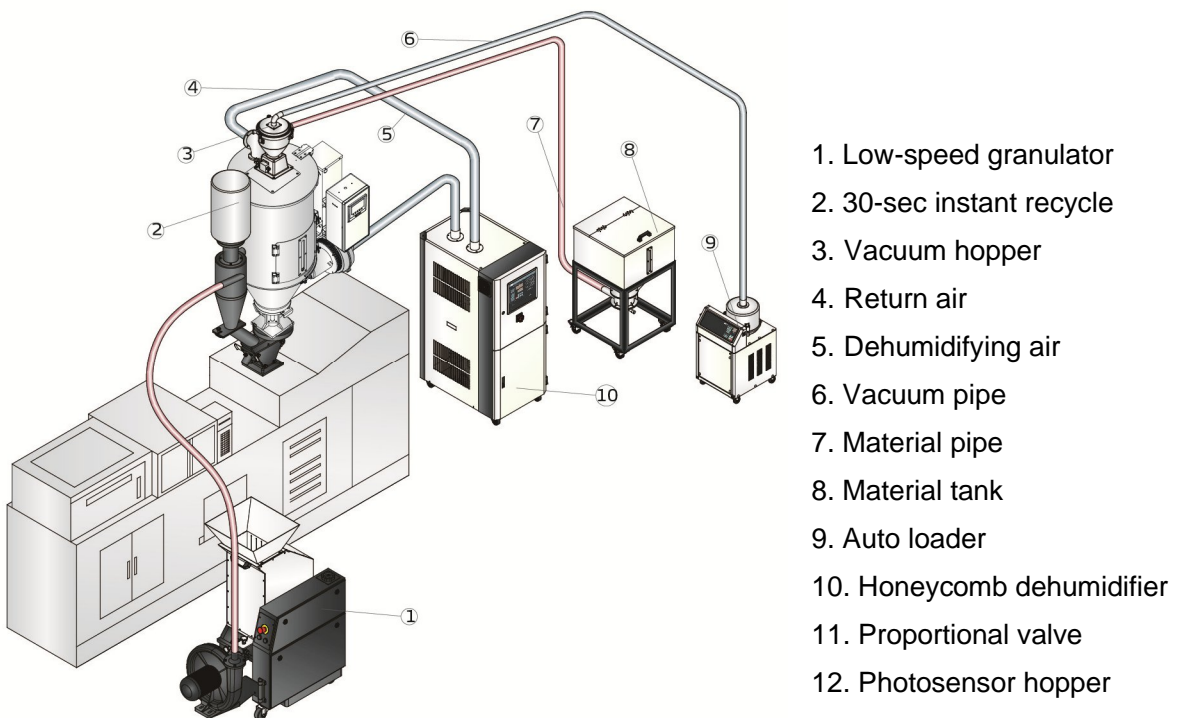

Picture 3-1: Direct Installation

Direct installation type is to mount the hopper dryer directly on the molding machine via a standard base. SEHD-12~300 is suitable for this mounting method

as well as floor stand installation type; SEHD-400 and models above should adopt floor stand installation type.

When using the method to mount the dryer, the equipped standard base must according to material inlet diameter of the molding machine mounting drill holes. Then use the screw to fasten the base and the molding machine inlet.

3.2 Floor Stand Installation

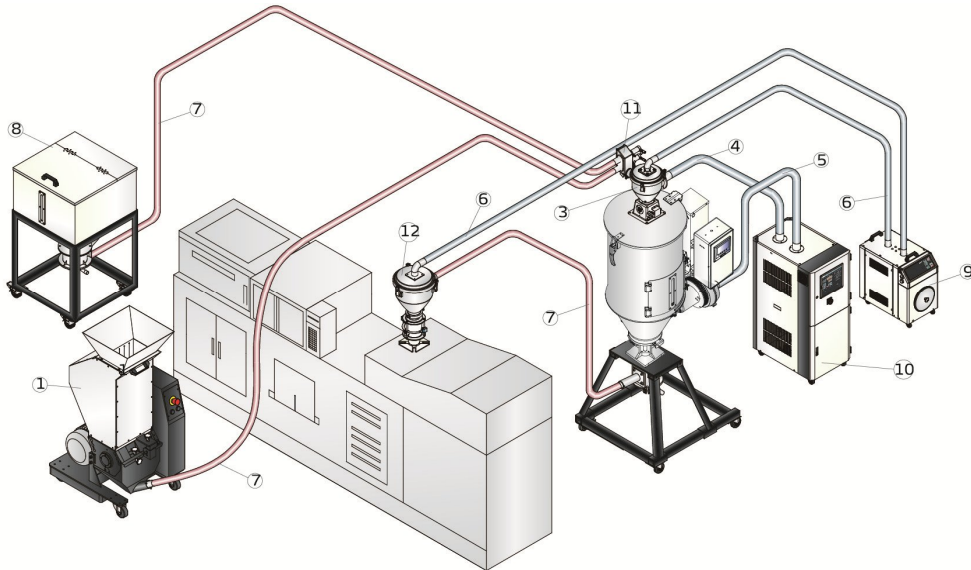

- | | | |
|----------------------------|---------------------------|------------------------|
| 1. Low-speed granulator | 2. 30-sec instant recycle | 3. Vacuum hopper |
| 4. Return air | 5. Dehumidifying air | 6. Vacuum pipe |
| 7. Material pipe | 8. Material tank | 9. Auto loader |
| 10. Honeycomb dehumidifier | 11. Proportional valve | 12. Photosensor hopper |

Picture 3-2: Floor Stand Installation

Floor stand installation type is to mount dryer on a floor stand, then via a photo-sensor hopper receiver to convey the material to the feed port of a molding machine. SHD-400 and above models should adopt floor stand installation type.

Machine should be placed on water-level floor to keep balance. If it is to be mounted on a high surface(e.g. on a scaffold or a interlayer), should ensure its structure and sizes can bear the weight and size of the machine.

3.3 Connecting the Power Source

According to circuit diagram of each machine to connect the power source. Notice should be taken concerning if the power voltage is in compliance with the required specifications, also if the switch and load are proper and safe.

Notes: Before connecting, the main switch should be off.

3.4 The Hopper Dryer Test

After ensuring all the circuits have been connected firmly, turn on the main switch to "ON" status and pressing the "RUN/STOP" button on control panel. Then blower runs, observe whether the rotating direction of the blower is same as the arrow indicated direction. If it is not, randomly exchange two of the three power firing lines and connect them firmly.



Picture 3-3: Blower

4. Operation Guide

4.1 Control Panel

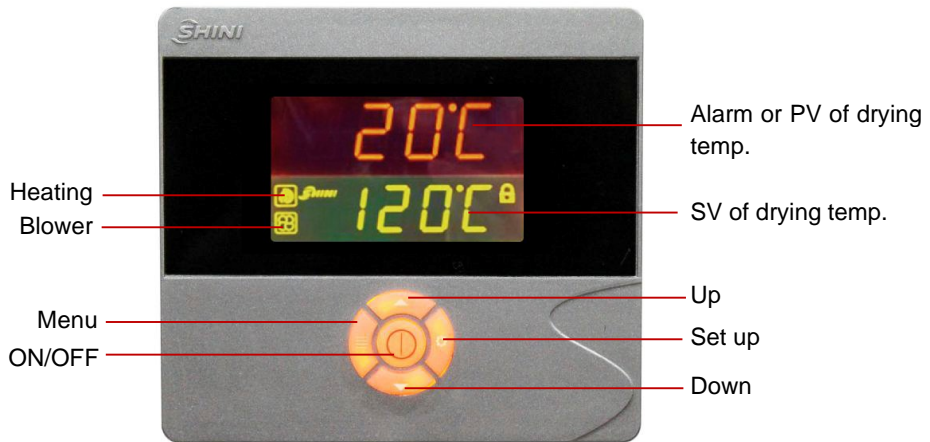

Picture 4-1: Control Panel

4.1.1 Panel Operation

- 1) Turn on main switch of control box.
- 2) Press <ON/OFF> key, it starts drying process, indicator turns green.
- 3) Press<ON/OFF> key again, the heater stops heating. The blower shutdown is delayed until the drying process is stopped, and indicator turns yellow.

4.1.2 Temperature Setting

- 1) The setup number will flicker after pressing <Meun> key, add or decrease temperature by pressing<Up>or<Down>key.
- 2) Press <Setup>key again to confirm the input value.

4.1.3 Temperature Lock

- 1) Press <menu> key for 2 seconds, it displays "TIME".
- 2) Press <Up>or<Down>key repeatedly, till it display "LOCK" .
- 3) Press <Setup>key, the set value flickers, press <Up>or <Down>key to select "YES"(lock temperature setting) and "NO" (don't lock).
- 4) Press <Set Key> to confirm if the temperature is locked.
- 5) Press<Menu>key to return operation menu.

Note: When the "LOCK" is set to "YES", the temperature setting will be locked that can't be changed, and the icons will appear on the interface.

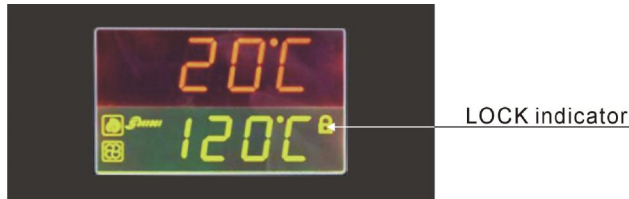

4.1.4 PID Setting

- 1) Press both <Menu> and <Down> keys for 3 seconds, it shows "P" (heating proportional band) setting.
- 2) Press <Setup> key, the set value flickers, then press <Up> or <Down> key to add or decrease the value.
- 3) Press <Setup> key to confirm the input value.
- 4) Press <Up> key again and again, it displays "I" (integral time) and "D" (differential time) setting accordingly.
- 5) Repeat above step 2 and step 3, input and confirm related parameters.
- 6) Press <Menu> key, it returns operation menu.

Notes: The PID parameter will directly influence the effect of temperature control, please be careful to set the value.

Parameters	Codes	Factory Default
Heating proportional band	P	5
Integral time	I	200
Differential time	D	30
Temperature for overheat protection	OTP	15°C
Heating switch cycle	HCLE	20S
Blower shutdown delay	FDLY	180S
Temp. unit	UNIT	°C

4.1.5 Intermittent Operation Setting

Hold<Menu> for about 2 secs. to set current time. Press <Up> or <Down> key to set the WEEK, AUTO (timer on/off), RPNE (the first time for intermittent operation), ROFF (the OFF time for intermittent operation), and RON (the ON time for intermittent operation).

4.1.6 One-week Timing Setting

- 1) Hold the <menu> for 5 secs, press <Up>or <Down>key to set OFF1 (Mon. off time), OFF2(Tues. off time), OFF3 (Wed. off time), OFF4(Thur. off time), OFF 5(Fri. off time), OFF6(Sat. off time), OFF7(Sun.off time).
- 2) Hold <Menu> for about 7S, press <Up> or <Down> key to set ON1(Mon. start time), ON2(Tues. start time), ON3(Wed. start time), NO4(Thur. start time), ON5(Fri. start time), ON6(Sat. start time), ON7(Sun. start time).

4.1.7 Communication Setting (optional functions)

- 1) Press both <Menu> and <Up> for 3 seconds, it displays “PRO” (communication protocol) setting.

Notes: communication protocol is fixed to Modbus RTU protocol—“RTU”.

- 2) Press <Up>or <Down>key to enter “ID” (communication address) setting.

Notes: The communication address of every controller in the same system must be the only one, no repeat use. In principle: communication address of hopper 1 is 1, communication address of hopper 1 is 2, and so on.

- 3) Press <Setup> key, the set value flickers, then press <Up>or <Down>key to add or decrease the value.
- 4) Press<Setup>key to confirm the input value;
- 5) Press <Up> key again and again, it displays “Baud” and “PAR” settings, (as below)
- 6) Repeat step 3 and step 4, then confirm the related input parameters.
- 7) Press<Menu> key to return operation menu.

Communication Parameters	Communication Codes	Factory Default
Communication Protocol	PRO	SH
Communication Address	ID	1(current address)
Baud Rate	BAUD	19.2K
PAR	PAR	none
Data Length	Data	8
Stop Bit	Stop	1

4.1.8 Operation Flow

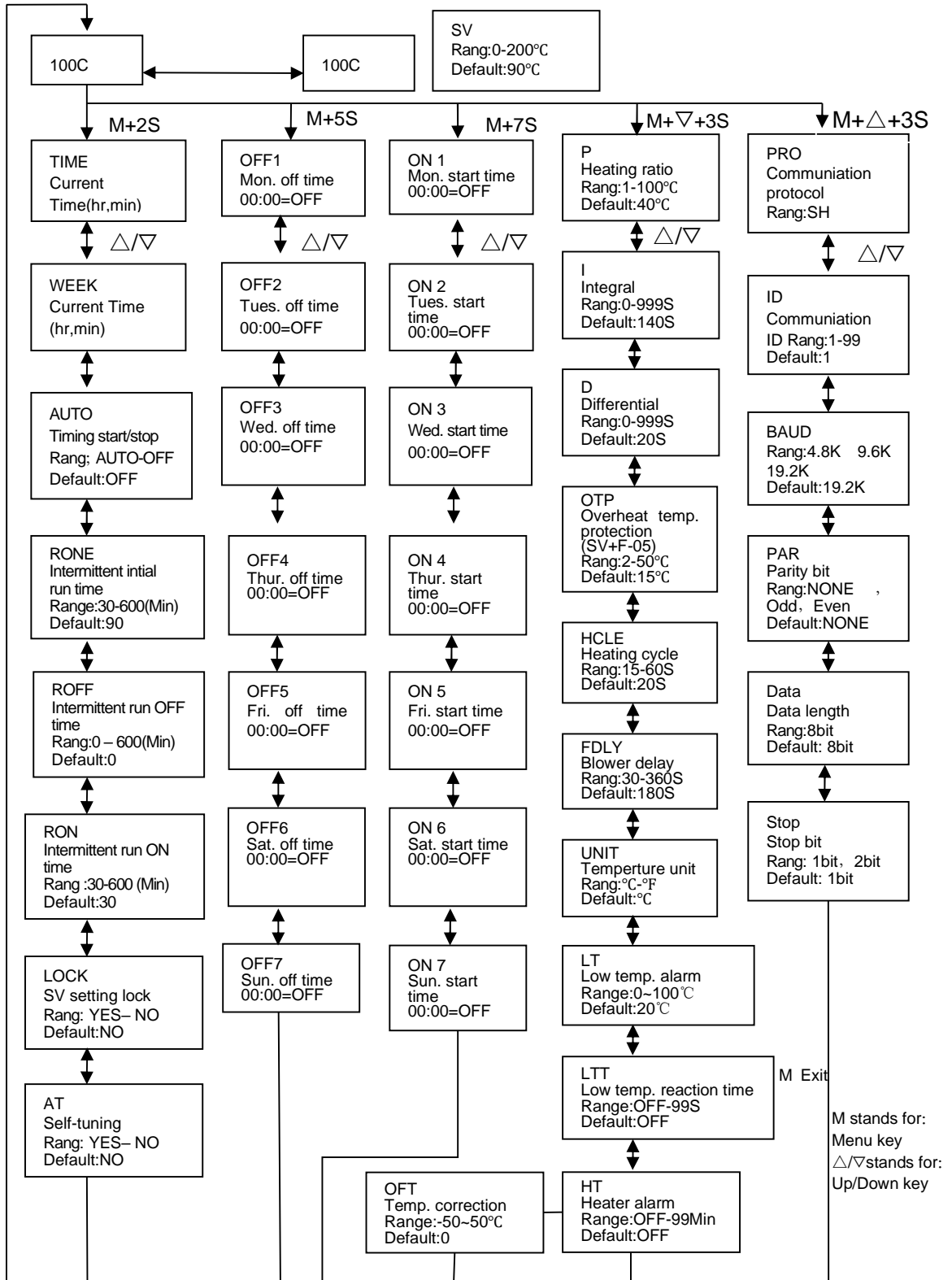

4.1.9 Wrong Codes Remark

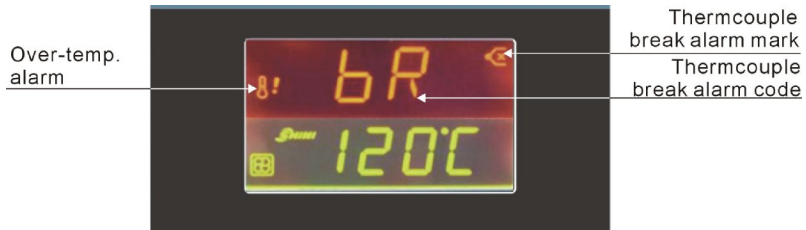

Wrong Codes	Remark
bR	Thermocouple break
oH	Overheat
REV	Temperature sensor reversely connected
oL	Overload
bAT	Battery error
EGO	EGO Over-temp
xATx	Auto-turning error
LT	Low temp. alarm
HT	Heater alarm

5. Maintenance and Repair

5.1 Blower

- 1) Clean the blower regularly (especially the air inlet path).
- 2) Eliminate the fan's dirt regularly to avoid the damage to the blower.

Note: No need for regular inspection because all the electrical parts in the control unit are fixed tightly!

6. Troubleshooting

Fault	Possible Reasons	Solution
Blower rotating on the contrary with arrow	Blower circuit connection reverse phase.	Replace any two of the three power live wires.
Blower not turning	<ol style="list-style-type: none"> 1. Motor fault. 2. Blower contactor is not closed. 	<ol style="list-style-type: none"> 1. Check and change. 2. Change or repair.
Blower not rotating and not heating	<ol style="list-style-type: none"> 1. Overload jumped. 2. The blower and pipe heater don't work 3. The transformer circuit breaker fault. 	<ol style="list-style-type: none"> 1. Overheat reset 2. Whether the blower works normally. 3. Check the replacement
No temperature for blower runs while	<ol style="list-style-type: none"> 1. Lead sheet of heater pipe melted. 2. Heater contactor fault. 3. Heater fault. 4. Controller fault. 5. Thermocouple fault. 	<ol style="list-style-type: none"> 1. Check and change. 2. Check and change. 3. Check and change. 4. Check and change. 5. Check and replace the thermocouple.
The blower can run but temperature is too low	<ol style="list-style-type: none"> 1. Lead sheet of heater pipe fault. 2. EGO broken. 3. The heater contactor is in phase shortage. 4. Controller is damaged . 	<ol style="list-style-type: none"> 1. Check and change. 2. Check or re-set. 3. Check and change. 4. Check the controller output and replace.
The blower can run but temperature is too high	<ol style="list-style-type: none"> 1. Hot-air pipe is jam. 2. Controller is fault. 3. Magnetic switch contacts stuck up. 	<ol style="list-style-type: none"> 1. Cleaning. 2. Replace the controller 3. Check the wiring.

Notes: Before inspecting or changing spare parts, ensure the main switch should be off.