



CFC-free Refrigerant Air-cooled Central Water Chiller

SICC-90A-R2



Refer carefully to this manual before operation.

SICC-A-R2 Series

■ Coding Principle

SICC - xxxA - xx

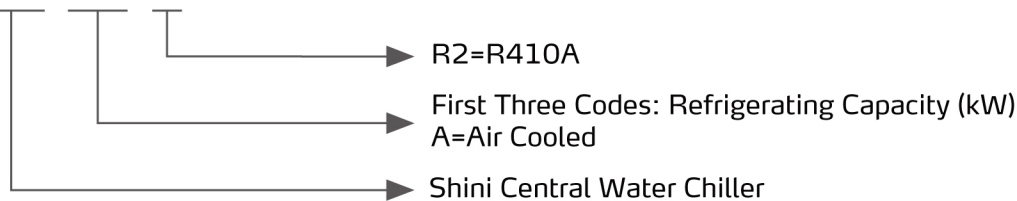

■ Features

- Modularized design makes it easier to combine module units 1-15. Cooling capacity can be enlarged by increasing the number of modules or choose appropriate modules to connect to existing system.
- The water route of the modules can be linked via linking one module to the inlet/outlet water tube. No need to install the inlet/outlet water tube for each module alone. The soft rubber tube is used to connect the modules, thus it is very convenient to construct.
- Adopt components like scroll compressor, expansion valve which ensure stable performance. The whole unit will not stop due to one module failure.
- When the unit starts up, the controller of the master unit will automatically ON/OFF and load of each module according to system load. Hence, lowering energy consumption during non-peak hours.
- Adopt electronic expansion valve to control the compressor exhaust temp. to prevent damage on system performance due to exhaust temp. rise.
- Link individual controller, capable of detaching any module to realize another cooling system.
- Protection grade: IP54.
- Equipped RS485 communication realizes remote monitoring and network function.

■ Application

SICC-A-R2 series are applicable for cooling moulds to reduce the product moulding cycle; they are also available in the cooling of equipment to maintain a normal temperature. Besides, they are suitable for other industries with the need for water cooling.

■ Working Principle

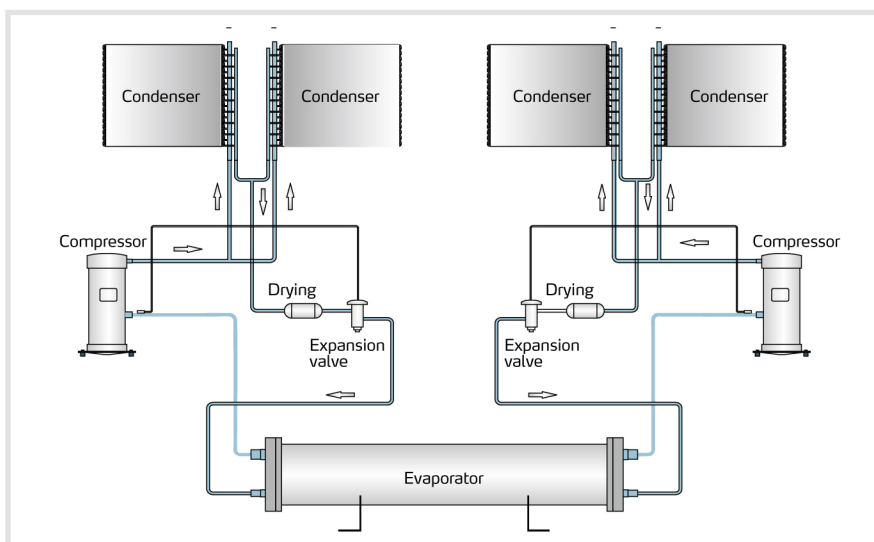

■ Outline Drawings

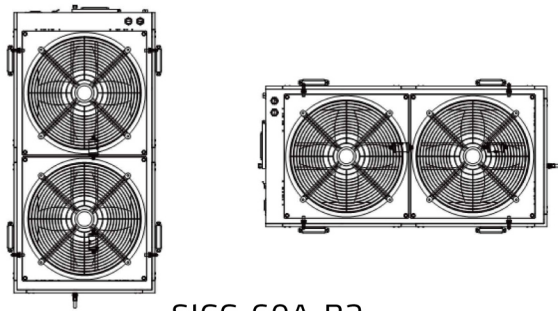
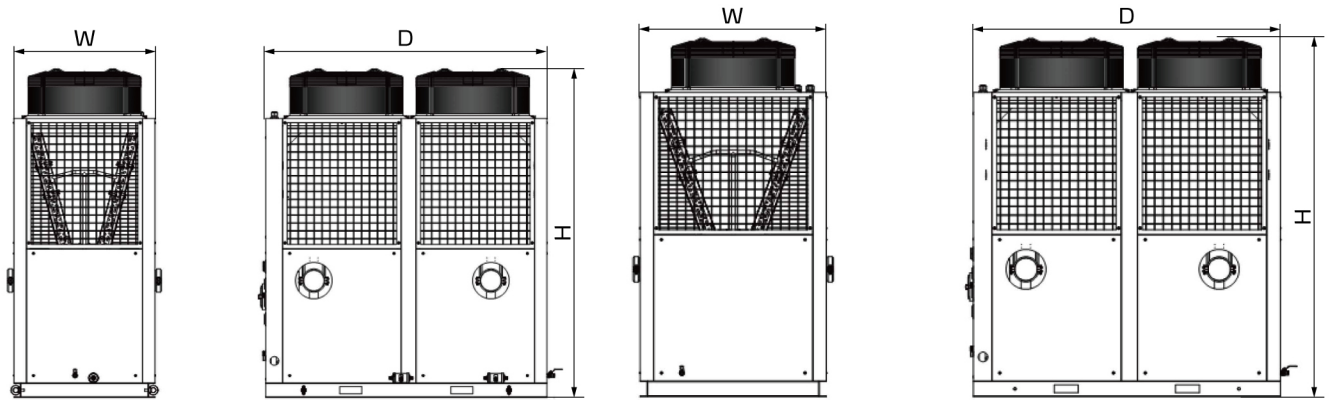

SICC-60A-R2

SICC-90A-R2

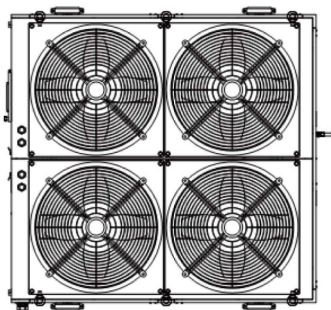
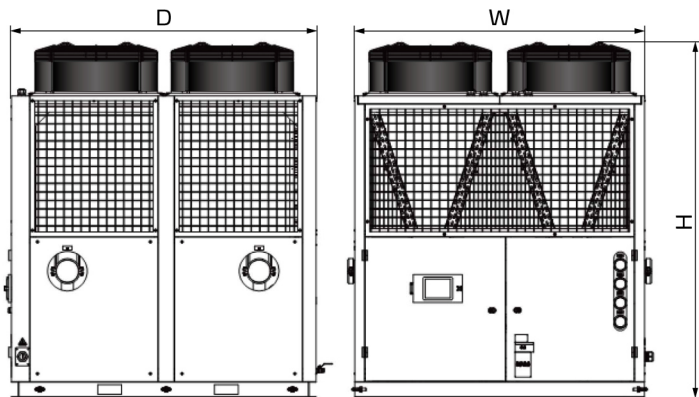

SICC-120A-R2

SICC-A-R2 Series

Modular combination

Installation

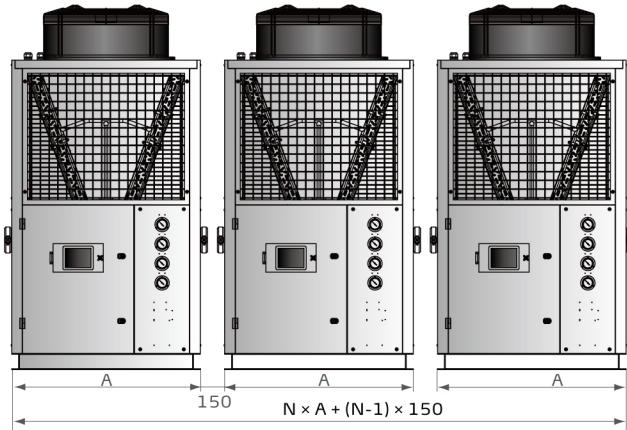

Type	Module Model	Model Dimension (A)	Combination Dimension
Module Unit	SICC-60A-R2	975	$N \times A + (N-1) \times 150$
	SICC-90A-R2	1170	
	SICC-120A-R2	1825	

Note: The installation clearance between module machines is 150mm to facilitate ventilation and condensation. The combination is shown in the figure.

Type	Model	Grouping	Compressor Power (kW)
Module Model	SICC-60A-R2	60A	17.2
	SICC-90A-R2	90A	25
	SICC-120A-R2	120A	34
Module Unit	SICC-150A-R2	60A + 90A	42.2
	SICC-180A-R2	2 × 90A	50
	SICC-210A-R2	90A + 120A	59
	SICC-240A-R2	2 × 120A	68
	SICC-270A-R2	3 × 90A	75
	SICC-300A-R2	2 × 90A + 120A	84
	SICC-330A-R2	3 × 90A + 60A	92.2
	SICC-360A-R2	3 × 120A	102

Type	Model	Grouping	Compressor Power (kW)
Module Unit	SICC-420A-R2	4 × 90A + 60A	117.2
	SICC-450A-R2	5 × 90A	125
	SICC-480A-R2	4 × 120A	136
	SICC-540A-R2	6 × 90A	150
	SICC-570A-R2	4 × 120A + 90A	161
	SICC-600A-R2	5 × 120A	170
	SICC-660A-R2	5 × 120A + 60A	187.2
	SICC-720A-R2	6 × 120A	204
	SICC-780A-R2	6 × 120A + 60A	221.2
	SICC-840A-R2	7 × 120A	238
	SICC-930A-R2	7 × 120A + 90A	263
	SICC-990A-R2	7 × 120A + 90A + 60A	280.2

We reserve the right to change specification without prior notice.



■ Specifications

Item		Model	SICC-60A-R2	SICC-90A-R2	SICC-120A-R2
Cooling ¹⁾ Capacity		kW	60	90	120
		kcal/hr	51,600	77,400	103,200
Cooling ²⁾ Capacity		kW	74	109	140
		kcal/hr	63,640	93,740	120,400
Power			3Φ, 400VAC, 50Hz		
Total Power		kW	19	28	37
Running Current		A	35	50	65
Startup Current		A	140	175	230
Compressor	Type		Scroll		
	Power	kW	8.6 × 2	12.5 × 2	17 × 2
	Crank Case Heater	kW	0.08 × 2	0.08 × 2	0.56 × 2
Refrigerant	Type		R410A		
	Filling amount	kg	15	17	26
Evaporator	Type		Tube-in-shell		
	Cooling Flow	m ³ /hr	10.3	15.5	20.6
	Pressure Loss	kPa	27	39.2	49
	Pipe Coupler	inch	5"Clamp	5"Clamp	5"Clamp
Condenser	Type		Fin Style		
	Blower Power	kW	1.49×2	1.49×2	1.49×2
	Air Quantity	m ³ /hr	9500×2	9500×2	9500×4
Machine Dimension	W	mm	975	1170	1825
		inch	38.4	46	71.9
	D	mm	1920	1920	1920
		inch	75.6	75.6	75.6
	H	mm	2250	2250	2250
		inch	88.6	88.6	88.6
Weight	Before Packing	kg	710	840	1200
		lb	1565	1852	2646
	After Packed	kg	780	900	1330
		lb	1720	1984	2932
Noise Level dB(A)		dB(A)	78	80	85
Unit Conversion			1 kW = 860 kcal/hr	1 RT = 3,024 kcal/hr	10,000 Btu/hr = 2,520 kcal/hr

Notes:

- 1) Cooling capacity is measured based on the flow of 0.172m³/(h.kW) and the outlet temperature 7°C/44.6°F of chilled water under the environmental temperature of 35°C/95°F.
- 2) Cooling capacity is measured based on the flow of 0.172m³/(h.kW) and the outlet temperature 15°C/59°F of chilled water under the environmental temperature of 35°C/95°F.
- 3) Machine operation conditions: ambient environment is at 15~43°C(59~109.4°F), chilling water temperature is at 8~25°C(46.4~77°F), for special requirements, the machine can be customized.

We reserve the right to change specifications without prior notice.

Shini Group

Addr: No. 23, Minhe St., Shulin Dist.,
New Taipei, Taiwan

Tel: +886 2 2680 9119

Fax: +886 2 2680 9229

Email: shini@shini.com

Factories:

- Taiwan
- Dongguan
- Pinghu
- Ningbo
- Chongqing
- Pune