



Energy-saving Intelligent Drying Control System

SEC-500H

**Energy-saving,
anti-excessive
drying**



Refer carefully to this manual before operation.

SEC-H Series

■ Coding Principle

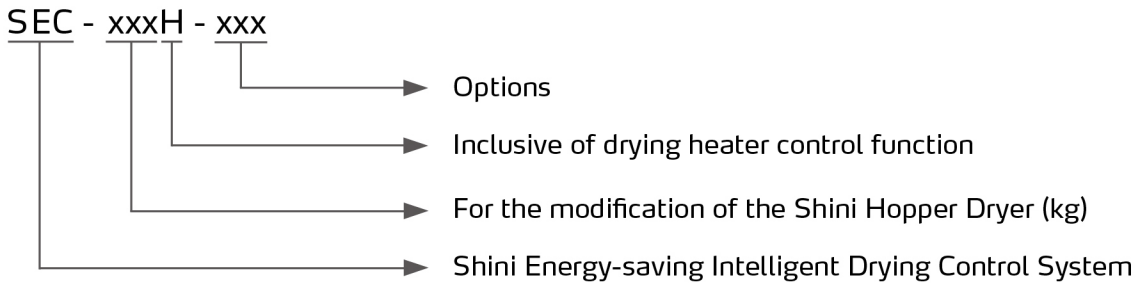

■ Features

- The unit can realize precision temperature control via a microcomputer PID controller.
- LCD display for easy operation;
The standard weekly timer can dry the material in advance to facilitate production.
- Overheat protection: When the drying temperature exceeds the protection value, the unit can cut off the heater power for safe operation.
- RS485 communication interface to realize industrial 4.0.

The unit can automatically regulate the drying airflow and temperature according to actual material throughput to realize energy-saving purposes and prevent over-drying. According to the materials and throughputs, the unit can realize 30%~80% energy reduction than the standard unit.

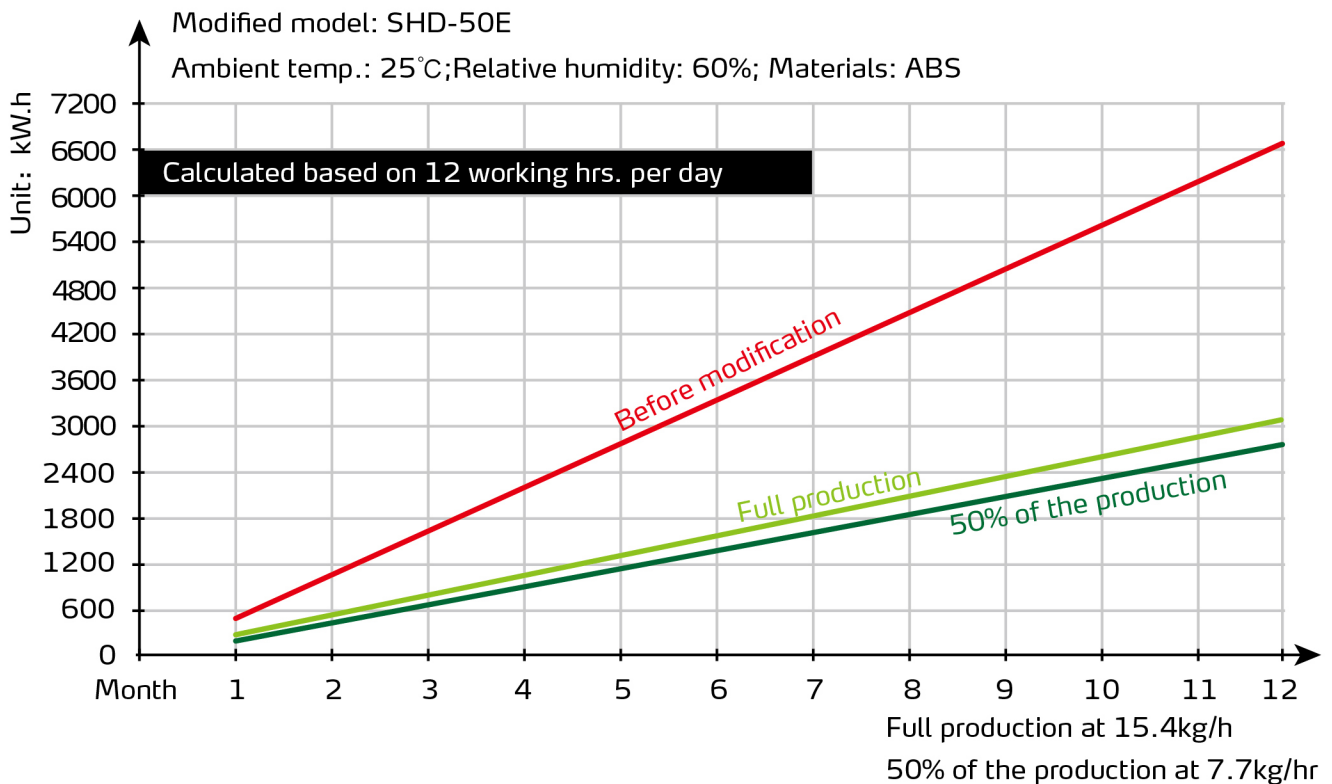

Application

The energy-saving intelligent drying control system SEC-H can be implemented and modified on most hopper dryers with three-phase blower. Besides, the energy-saving intelligent drying control system SEC-SH can be implemented and modified on most hopper dryers with single-phase blower. Remove the original control system of the hopper dryer and replace it with the Shini energy-saving intelligent drying control system, which can save 30%~80% energy consumption according to different blower airflows and environments.

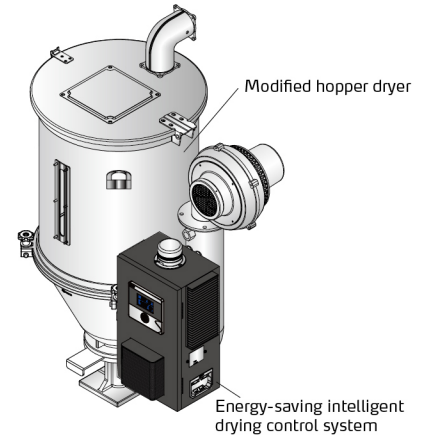

Working Principle

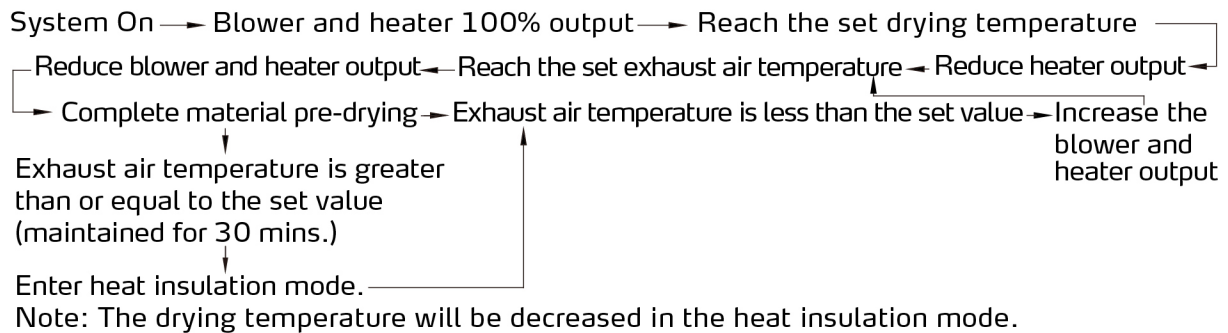

Outline Drawings

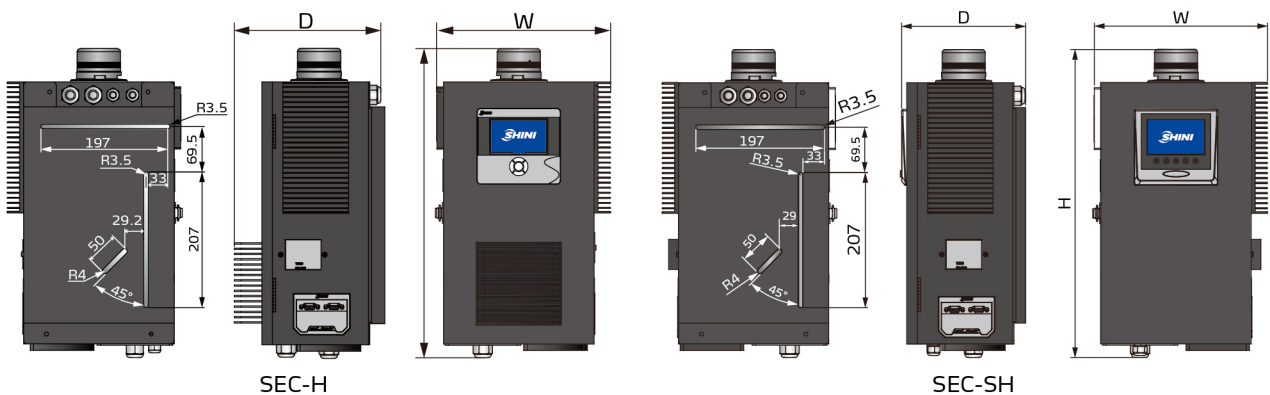

Specifications

Model	SEC-150H	SEC-500H	SEC-600H	SEC-75SH	SEC-150SH
Max. compatible heater power (kW)	7.2	19.2	19.2	4.2	7.2
Max. compatible blower power rating (kW)	0.6		1.5	0.6	
Compatible heater voltage (VAC)	3 Φ, 400VAC			1 Φ, 230VAC	3 Φ, 400VAC
Compatible blower voltage (VAC)	3 Φ, 400VAC			1 Φ, 230VAC	1 Φ, 230VAC
WxDxH(mm)	265×223×472		370×219×631	240×195×472	265×190×472
Weight(kg)	10		20	10	

Notes: Power: 3 Φ, 400VAC, 50Hz

Shini Group

Addr: No. 23, Minhe St., Shulin Dist.,
New Taipei, Taiwan

Tel: +886 2 2680 9119

Fax: +886 2 2680 9229

Email: shini@shini.com

Factories:

- Taiwan
- Dongguan
- Pinghu
- Ningbo
- Chongqing
- Pune

2026-06-15-04 Copyrights Reserved.

www.shini.com